



products

By K&A Manufacturing Inc.

TOOLS REQUIRED FOR ASSEMBLY:
Cordless Drill W/ #2 Phillips Head Bit
7/16"/12mm Wrench, Tape Measure

100CPU/100CPU-DO INSTALLATION INSTRUCTIONS

Parts List		
ITEM	QTY	DESCRIPTION
A	1	100 CPU Assembly
B	4	#10x3/4" Round Washer Combo

Instructions

1. Measure the height, depth, and width of the CPU being installed.
2. Loosen all fasteners. Set the CPU height (Adjustment #1). Tighten fasteners.
3. Install (A) 100CPU in its final position on the worksurface using (4) (B) 3/4" fasteners.
****Make sure to account for the CPU depth and width****
4. Insert the CPU in the (A) 100CPU. Set the CPU width (Adjustment #2) using the tee-handles to tighten.

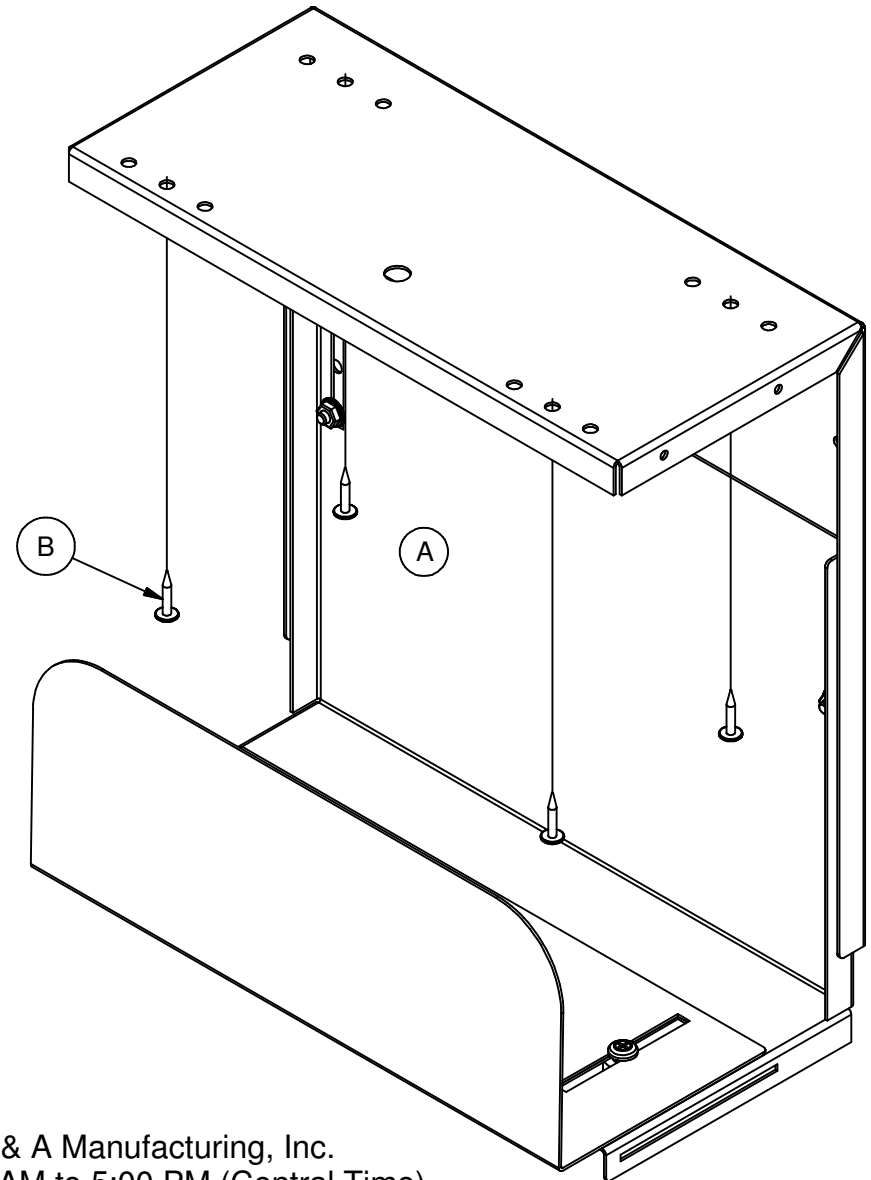
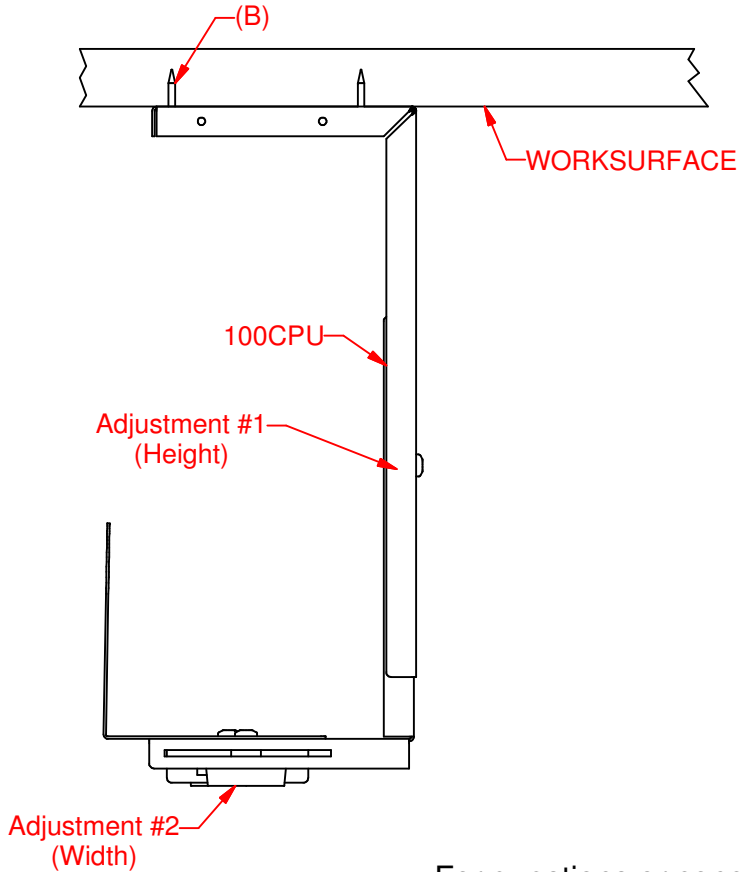

For questions or concerns, please call K & A Manufacturing, Inc.
1-800-298-4351 available Monday-Friday 8:00 AM to 5:00 PM (Central Time)